

Description

The **FIRE KILL™** system for protection of OH1 office and accommodation false ceiling and false floor is unique as it requires very low water pressures and water flow rates.

The system utilized the Automatic Low Pressure Water Mist Nozzles Model OH-DC2 which are patented automatic, upright, fine water mist nozzles.

The OH-DC2 nozzle creates a homogenous fine water mist, which absorbs heat, reduces radiant heat and causes oxygen depletion near the fire, which in turn controls and suppresses the fire. This homogenous spray consists of a high concentration of very small droplets. Because of the small mass of the droplets, the nozzle creates a large coverage, further minimizing the water expenditures and hydrating nearby combustibles.



Approvals

The **FIRE KILL™** OH- nozzle has been successfully tested to VdS, 3883-3en. Fire Test Protocol for Water Mist Systems and EN14972:2020 Part6: Protection of false ceilings and false floor of OH Group 1.

Technical data

General Description	
Minimum water pressure	8 bar
Maximum working pressure	16 bar
K-factor (metric)	13,85 (l/min/√bar)
Nominal release temp.	57°C
Other nominal release temperatures	68°C, 79°C, 93°C
Time Response Index (metric)	RTI < 50 Fast Response Class
Drop size	DV90 < 300 µm
Application General	
Height (max)	0,80 m
Height (min)	0,30 m
Nozzle Min distance to surface	0,05 m
Minimum distance between nozzles	2.00 m
Minimum system operation time	60 minutes
Minimum design area	Unlimited
Application Area Coverage	
Spacing (max)	4.5 m x 4.5 m
Distance to wall (max)	1.80 m
Hydraulic System Area Coverage	
Water capacity design	6 nozzles
Pump capacity min.	235 l/min
Specific Description	
Weight	0.211 kg (≈0' 465 lbs)
Housing	Brass
Coating	NiSn
Strainer	Stainless Steel
Thread	½" BSP/BSP-T/NPT
Standard Finish	Chrome, White RAL 9010
Other Finish	Other RAL colors

Dimension

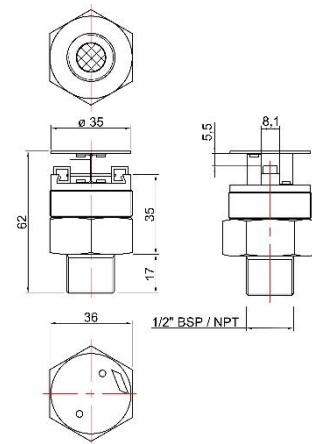

Other Products in the system	
Name	Model
Alarm Check Valve	WAC
Pre-Action valve	C-EL PA
Nozzle spanner	OH-S42

Installations

The OH-DC2 upright nozzle is installed in open pipe work with the nozzle cover plate 50 mm below the false floor. The nozzles can be rendered further nonvisible through customization of the Cover Plate; this involves changing the color-finish from the standard Chrome or White RAL 9010 to any other RAL colors.

The FIRE KILL™ OH-DC2 should only be installed in clean, non-corrosive pipe systems, which do not cause galvanic corrosion to the nozzle, the system components and pipe hangers, and with clean rinsed internal surfaces free of impurities. The water quality should be free of chlorides and impurities. The system should be installed using materials found acceptable by the authorities having jurisdiction.

Caution

The FIRE KILL™ OH-DC2 is a fragile component, containing a glass release element under pressure. Only VID OH-spanners should be used in the installation of the FIRE KILL™ OH-DC2 nozzle.

Dropped or otherwise damaged nozzles should not be reinstalled.

Contact

For further information on FIRE KILL™ products, please contact our sales department at Sales@vidfirekill.com

VID Fire-Kill APS is not responsible for any errors or omissions, or for the results obtained from the use of this information. All information in this document is provided "as is", with no guarantee of completeness, accuracy, functionality, timeliness or of the results obtained from the use of this information.