

Description

The FIREKILL™ Low Pressure Water mist nozzle OH-AC100 is an automatic, pendent low-pressure water mist nozzle ideal for such as fire protection of accommodation areas and other similar locations with smooth ceilings and walls. The different finishes and optional painted finishes make the system blend in with almost every type of surface.



Approvals

The FIREKILL™ OH-AC100 has been tested in accordance with VdS Fire test protocol for water mist system, protection of Office Spaces and Accommodation Areas.

The FIREKILL™ OH-AC100 can therefore be used for securing accommodation areas, as well as any other comparable risk.

Technical data

General Description	
Minimum water pressure ^{NOTE 2}	8,0 bar
Maximum working pressure	16 bar
K-factor (metric)	10,0 (l/min@1 bar)
Inlet orifice	5,00 mm
Nominal release temperatures	57°C ,68°C, 79°C, 93°C, 141°C
Time Response Index (metric)	RTI < 50 Fast Response Class
Drop size	DV90 < 300 µm
Application	
Coverage each nozzle ^{NOTE 1}	12.25 m ² (3,5m x 3,5m)
Distance to wall (max)	1,75 m
Height (min - max)	2,0 - 4,0 m
Distance below ceiling	10 – 15 mm
Specific Description	
Weight	0.211 kg
Housing	Brass
Coating	NiSn
Strainer	Stainless Steel
Thread	½" BSP/BSP-T/NPT
Standard Finish	Chrome, White RAL 9010
Other Finish	Other RAL colors
Hydraulic System	
Water density	2.30 mm/m ²
Minimum system operation time	60 min
Minimum design area	72 m ² / 6 nozzles

Other products to be installed in the system

Name	Model
Alarm Check Valve	WAC
OH Rosette	OH-R3T
OH Pipe Spanner	OH-S42

Dimension

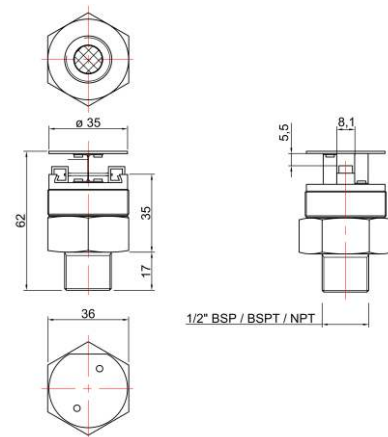

Spray pattern (Preliminary)

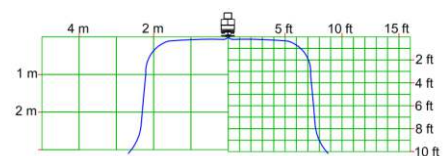

Installations

The OH-AC100 nozzles are installed recessed in the ceiling, using the OH-S42 nozzle spanner, as not to damage either nozzle or the surrounding ceiling.

The FIREKILL™ OH-AC100 should only be installed in clean, non-corrosive pipe systems, which do not cause galvanic corrosion to the nozzle, the system components and pipe hangers, and with clean rinsed internal surfaces free of impurities. The water quality should be free of chlorides and impurities. After successful installation of the nozzle, the OH-R3T rosette is to be screwed on to the nozzle, thus completing the installation process. The nozzle may also be surface mounted into open pipe work. The system should be installed using materials found acceptable by the authorities having jurisdiction.

Nozzle Position

The nozzles are to be installed in the pendant position, making them lie perpendicular to the surface of the ceiling.

Caution

The FIREKILL™ OH-AC100 is a fragile component, containing a glass release element under pressure. Only VID OH-spanners should be used in the installation of the FIREKILL™ OH-AC100 nozzle.

Dropped or otherwise damaged nozzles should not be reinstalled.

Contact

For further information on FIREKILL™ products, please contact our sales department at Sales@vidfirekill.com

VID Fire-Kill APS is not responsible for any errors or omissions, or for the results obtained from the use of this information. All information in this document is provided "as is", with no guarantee of completeness, accuracy, functionality, timeliness or of the results obtained from the use of this information.