

Description

The FIRE KILL™ Model F is a patented system of compact high capacity in-line style filters, for protection of small openings and orifices and small capacity filters and clearances against clogging, and for protection against abrasive wear of internal surfaces in pipe systems transporting liquids.

The Model F filters have been tested with full contamination load in water to the International Maritime Organization (IMO) clogging test standard for water mist systems MSC 1165 and IMO MSC 265(84).

The Model F is to be used with all VID Fire-Kill open and automatic nozzles to ensure that no clogging will occur.

Application

- Low pressure water mist systems
- Water spray systems
- Heating and Industrial pipe systems



Technical data

Specification	
Pressure loss	DN 50 - 0.1 bar (0-500 l/min)
	DN80 - 0.1 bar (0-2000 l/min)
Working Pressure	16 bar
Test pressure	24 bar
Material	AISI 316
Connection	Flanged DIN PN16
Filter size	310 micron
Pressure gauge	0 – 25 Bar
Weight Kg	DN 50 – 8,80 Kg
	DN 80 – 12,50 Kg

Maintenance

Model F filters are designed for easy service due to the flanged style installation. The filter should be maintained on a regular basis based on use and water quality.

Dimension

	DN 50	DN 80
H1	220 mm	300 mm
H2	270 mm	350 mm
OD	ø 165 mm	ø 200 mm
L1	133 mm	150 mm
øK	ø 125 mm	ø 160 mm
øA	4 x ø 18 mm	8 x ø 18 mm
øGauge	ø 68 mm	ø 68 mm

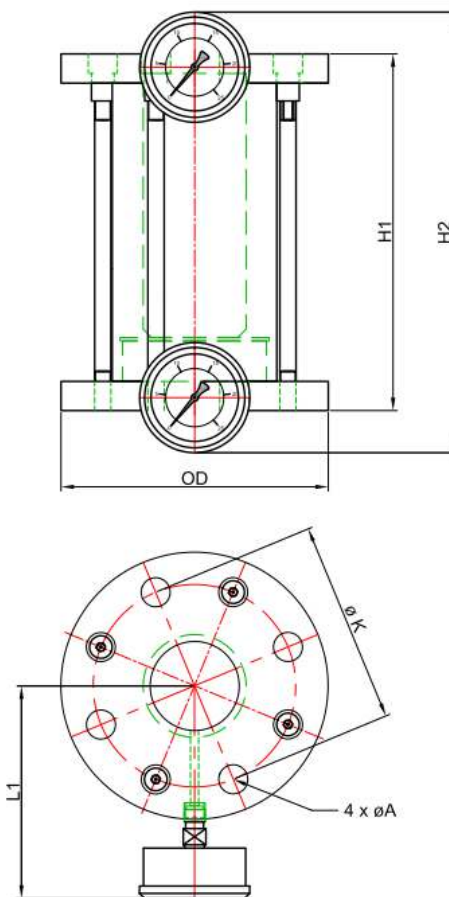

Contact

For further information on FIREKILL™ products, please contact our sales department at Sales@vidfirekill.com

VID Fire-Kill APS is not responsible for any errors or omissions, or for the results obtained from the use of this information. All information in this document is provided "as is", with no guarantee of completeness, accuracy, functionality, timeliness or of the results obtained from the use of this information.