

Description

The FIRE KILL™ Model F102-1 Fire Protection Nozzle is a telescopic nozzle utilizing low pressure water mist to provide fire protection in hangar areas below aircrafts.

The nozzle is installed embedded into the hangar floor, flush with the surrounding surface. Once pressure is added to the nozzle pipes, the nozzle will elevate from the floor and spray water mist into a 2 by 4 meter area.

References

The Model F102-1 nozzle have been installed in NATO hangars for fire protection of F16, F35, helicopter hangars and Boeing AWAC airplanes. The nozzles has been full scale tested att an ISO 17025 accredited test laboratory with various types of fuels such as Jet Fuel, Heptane and Diesel.

The test has been typically 4 m2 pool fires, 1 m2 pool fires with wood crib, obstructed 1 m2 pool fires, flowing jet fuel fires etc.



Technical data

General description	
Materials	SS AISI 316
Minimum Water Pressure	10 bar
K-value	12 (l/min/√bar)
Thread	3/4" BSPT Female
Spacing	
Distance between neighboring nozzles	2 m
Distance between opposing nozzles	8 m
Related Products	
Flame detector	Model Deflametec
Control valve	Model C-EL

Dimension

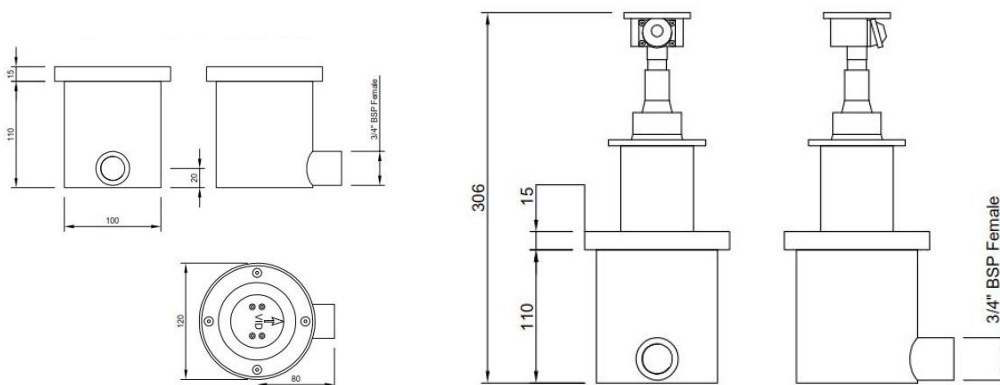

Installation

The Model F102-1 nozzles are to be placed opposite each other, as to spray against each other at a maximum distance of 8 m; nozzles next to each other should not have a larger spacing than 2 m.

If the area is wider than 8 m, extra sets of nozzles should be placed overlapping the original nozzles with 0.5m and shifting 1 m, as to place a nozzle between two of the original nozzles. If there are aircrafts where the distanced between the engine and the hangar floor is limited, typically 0,5 to 1,5 meter, additional nozzles should be installed, minimum one at the front and one at the end of the engine pointing towards each other. Distance between the two nozzles, max 5.5 m.

The Model F102-1 is to be installed 125 mm into the hangar floor as to keep the top of the housing flush with the surrounding floor.

The Model F102-1 consists of a Nozzle House, a Nozzle Insert Part and a Top Seal. The Nozzle house along with the Top Seal and the pipe system should be installed during construction of the hangar floor. After the floor construction is completed, the Top Seal should be removed, and the system should be continuously flushed, to remove all possible impurities. Once the pipe system has been flushed, the Nozzle Insert Part is installed. Hereafter the nozzle system is activated, and the nozzle sprays are checked prior to commissioning.

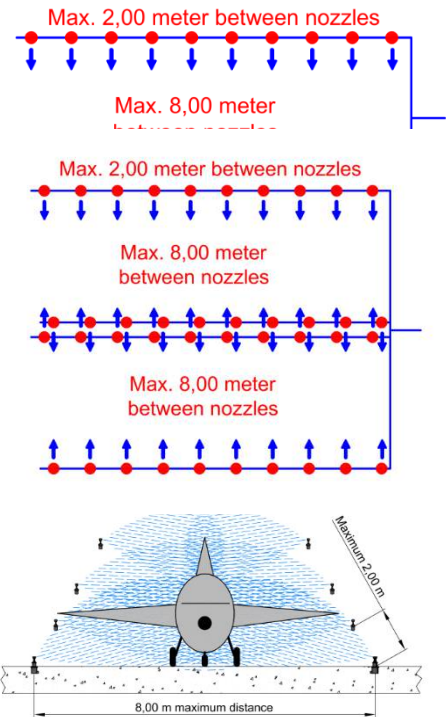

Caution

Should the Model F102-1 nozzle or a part of it become compromised or suspected compromised, the nozzle should be replaced and returned to the manufacturer for testing.

Contact

For further information on FIRE KILL™ products, please contact our sales department at Sales@vidfirekill.com

VID Fire-Kill APS is not responsible for any errors or omissions, or for the results obtained from the use of this information. All information in this document is provided "as is", with no guarantee of completeness, accuracy, functionality, timeliness or of the results obtained from the use of this information.